

1. CABLE:

CONDUCTOR:

30 AWG SOLID SILVER PLATED COPPER.RF

INSULATION:FOAM POLYOLEFIN.

PAIR:2 SINGLES LAID FLAT AND PARALLEL.

DRAIN WIRE:32AWG SOLID SILVER PLATED COPPER.

PAIR SHIELD:ALUMINUM/POLYESTER TAPE.ALUMINUM SIDE FACING IN 25% OVERLAP. COLOR- YELLOW.

INNER SHIELD:ALUMINUM/POLYESTER TAPE,ALUMINUM SIDE PACING OUT,25% OVERLAP.

OUTER SHIELD:38AWG TIN PLATED COPPER BRAID ,85% COVERAGE.

JACKET: PVC OUTER DIA: 4.6±0.20mm NOMINAL. COLOR:BLACK.

DIFFERENTIAL IMPEDANCE:100±5 OHMS @TDR.

UL LISTED: UL20276.

2. CONNECTOR:

P1&P2: SFP+ MODULE.

<1> HOOD:ZINC DIE CASTING,NICKEL PLATING.

<2> LATCH: PC RESIN 94 V-0,COLOR IN BLACK.

<3> P.C.B: 4 LAYERS,M6. 30μ" HARD GOLD ON CONTACTS.

<4> EEPROM: 24C04.512BYTE.

3. PULL TAB: COLOR:BLACK.

4. PACKING

1. EVERY PRODUCT PACKED IN ANTI-STATIC BAG.

L ≤ 3M, SIZE: 0.06*25*30, L > 3 M, SIZE: 0.06*30*40.

2. PACKED IN A 46*30*26CM CARTON.

L=1M/2M/3M, USE ONE FOR EVERY 100 CARTON PACKING

L=5M, USE ONE FOR EVERY 30 CARTON PACKING

3. REMARKS: ALL MATERIALS OF THIS PRODUCT ARE IN LINE WITH ROHS.

25G SFP30AWG

MATERIALS:

ITEM	DESCRIPTION	QTY	UNIT
1	CABLE:UL20276 30AWG*1P+D+AL+M.Y)*2 P+AEB (25G) BLACK OD:4.6mm	1	PCS
2	CONN: SFP+ SHELL	2	SET
3	PCB: SFP+ PCB	2	PCS
4	COPPER FOIL:W*L=5*40MM	2	PCS
5	VELCRO:W*L=10*70MM	2	PCS

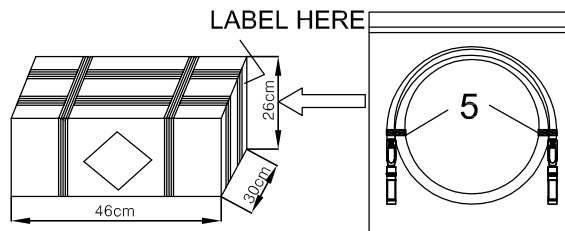

 深圳市凯鸿创电子科技有限公司 SHEN ZHEN KHC Electronic Technology CO.,LTD				MATERIAL NO.: KHCZSFP30XXXXX	
APPROVED		DESIGN	STONE	CUSTOMER NO.: 25GZSFP_30AWG	
REVIEW		CHECK	ELLA		
SCALE	1:1	DATE	2019.08.08	DRAW NO.:	共2页 第1页

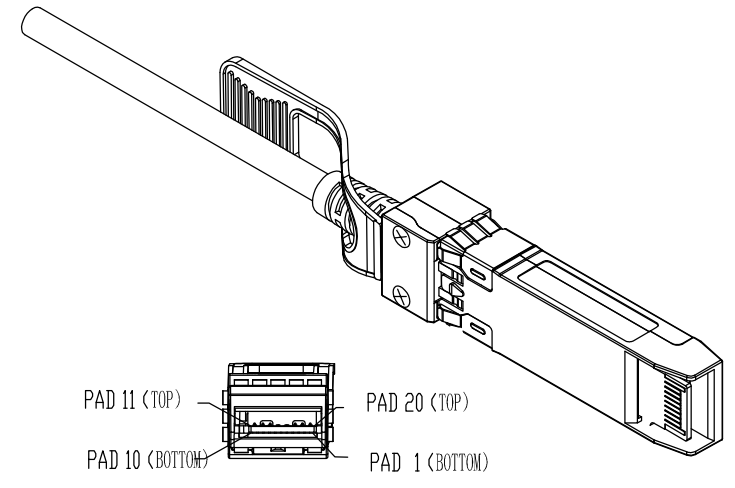
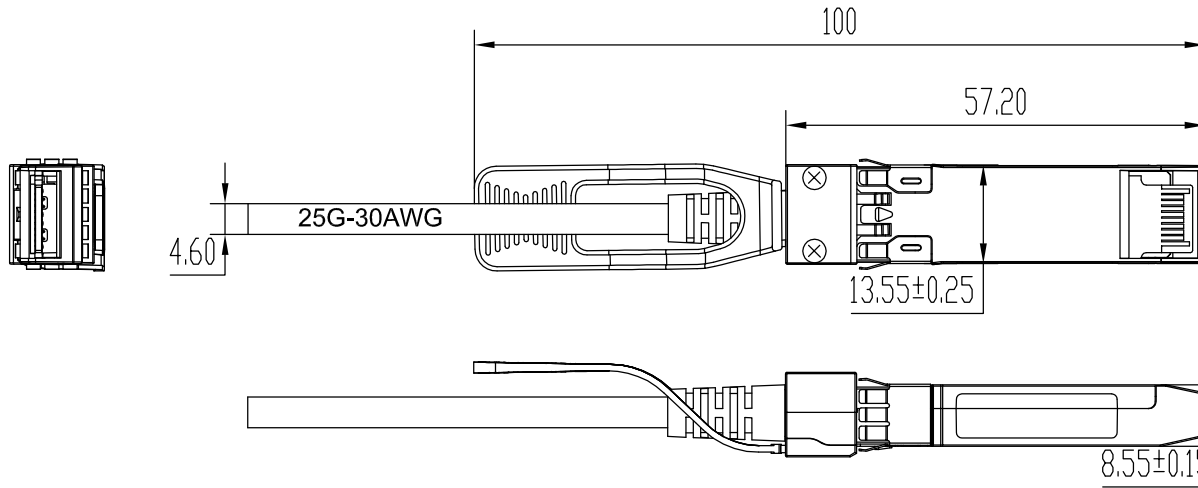

WIRING DIAGRAM				
P1 END			P2 END	
PAD	SIGNAL		PAD	SIGNAL
12	RD -	←	19	TD -
13	RD +	←	18	TD +
18	TD +	→	13	RD +
19	TD -	→	12	RD -

LOW SPEED SIGNALS	
SFP+	
PAD	SIGNAL
02	Tx_Fault
03	Tx_Disable
04	SDA
05	SCL
06	Mod_ABS
07	RS0
08	Rx_LOS
09	RS1
15	VccR
16	VccT

TABLE1 (25G_ZSFP)		
P/N	LENGTH	TOLERANCE
KHCZSFP3000500	0.5 M	±30
KHCZSFP3001000	1 M	±30
KHCZSFP3001500	1.5 M	±30
KHCZSFP3002000	2 M	±30
KHCZSFP3003000	3 M	±50

LABEL

Supplier: KAI HONG CHUANG

Supplier P/N: _____

Customer P/N: _____

P/O Number: _____

Quantity: _____

EX-factory Date: _____

Rohs:

深圳市凯鸿创电子科技有限公司 SHEN ZHEN KHC Electronic Technology CO.,LTD				MATERIAL NO.: KHCZSFP30XXXXX	
APPROVED		DESIGN	STONE	CUSTOMER NO.: 25GZSFP_30AWG	
REVIEW		CHECK	ELLA		
SCALE	1:1	DATE	2019.08.08	DRAW NO.:	共2页 第2页